

PROTECTION SYSTEM FOR FUTURE LV MICROGRIDS

Hannu LAAKSONEN
University of Vaasa – Finland
hannu.laaksonen@uwasa.fi

Kimmo KAUHANIEMI
University of Vaasa – Finland
kimmo.kauhaniemi@uwasa.fi

Sampo VOIMA
University of Vaasa – Finland
sampo.voima@uwasa.fi

ABSTRACT

Traditional protection of low voltage (LV) network will not be applicable for future LV microgrids and new adaptive protection system must be developed. In this paper adaptive protection system for LV microgrid during normal and island operation will be presented. Adaptivity means that protection system will e.g. change settings of LV feeder protective devices (PDs) according to the operation state of the LV microgrid, i.e. normal or island operation, and in the settings of LV feeder PDs also the number and type of DG units connected to the corresponding LV feeder and also their fault current feeding capabilities will be taken into account. Fast and selective operation between different PDs is achieved by intelligent utilization of high-speed communication.

INTRODUCTION

Realization of future Smart Grids with island operation capability i.e. microgrids, requires that all technical issues such as power and energy balance, power quality and protection, are solved. One of the most crucial one is the protection of LV microgrid during normal and island operation. Nowadays only low-cost protection devices are used in LV networks, which have very low degree of flexibility. For example conventional fuses cannot be parameterized and switches with integrated relays do not offer communication functionalities, their operation curves are fixed and the definition of different setting groups is not allowed [1]. The conventional protection in distribution networks is designed to operate for high fault current levels in radial networks, but during island operation of the microgrid high fault currents from the utility grid are not present. Also most of the DG units that will be connected to the LV microgrid in the future are converter interfaced and have limited fault current feeding capabilities. Considering all the possible operation states in LV microgrids, a traditional overcurrent protection with a single setting group will not be able to guarantee selective trips for all type of faults that can happen. This means that the traditional protection of LV network will not be applicable for LV microgrids and therefore new adaptive protection system must be developed. However, the adaptive LV microgrid protection system must be economically feasible and therefore it cannot be too complex [1].

In the development of the new protection scheme for LV microgrids many things must be considered including number of protection zones in LV microgrid, speed requirements for microgrid protection in different operation states and configurations and protection principles for parallel and island operation of the microgrid. In addition

the developed protection scheme for microgrid must be supported by the technical choices made in the microgrid operation and control systems.

The size and number of LV microgrid protection zones will define the needed amount of PDs for microgrid protection. There are two main reasons for speed requirements of LV microgrid protection: stability and customer sensitivity. Stability needs to be maintained after sudden changes i.e. after islanding due to fault in MV network during parallel operation with utility grid or after fault in LV microgrid during island operation. Especially directly connected rotating machines are very sensitive to lose stability in voltage dips caused by faults in island operated microgrid and so they may jeopardize the stability of the whole microgrid. For that reason protection should operate in islanded microgrid rapidly in every kind of faults and, e.g., if microgrid customers have fuses with high rated currents on larger customers there is a risk that customer protection may operate too slowly in island operation due to low fault currents, which in turn may cause instability in island operated microgrid after fault clearance.

In this paper adaptive protection system for LV microgrid during normal and island operation will be summarized based on extensive PSCAD simulation studies done previously for [2] and [3]. Also the operation curves for different PDs in LV microgrid protection system during normal and island operation will be described. More details about issues related to the LV microgrid protection and to the proposed LV microgrid protection system can be found from references [2] and [3].

NEW LV MICROGRID PROTECTION SYSTEM

In Fig. 1 the LV microgrid protection zones and types of protective devices (PD 1-4) chosen for the new LV microgrid protection system are presented.

The needed protection devices (PD 1-4) are

- PD 1: Microgrid protection
- PD 2: LV feeder protection
- PD 3: Customer protection
- PD 4: DER unit protection

In the proposed LV microgrid protection system for example LV feeders are protected in addition of traditional fuses with protective relays that have adaptive multi-criteria algorithms and fast standard based communication capabilities (Fig. 1). In addition, the protection algorithm of PD 2s is able to adapt to the current network configuration as well as to states of the DER units during island operation (Fig. 1). In practice Microgrid Management System (MMS) should be used to change settings and pick up limits of protection devices (PD 2s) when microgrid configuration changes (Fig. 2).

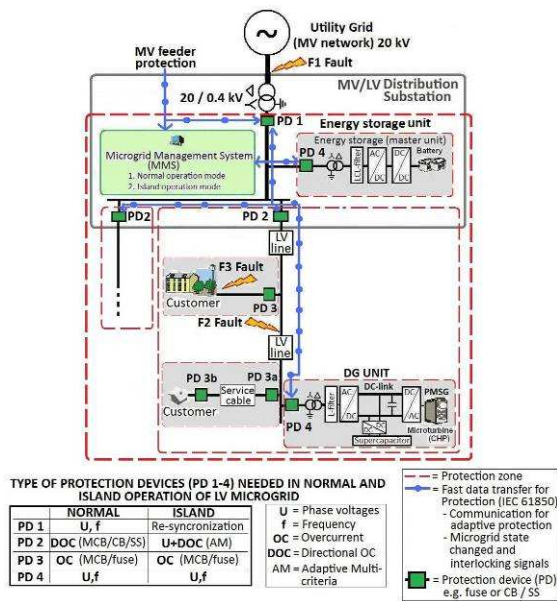

Figure 1. The protection zones and types of protection devices (PD 1-4) needed in normal and island operation of LV microgrid.

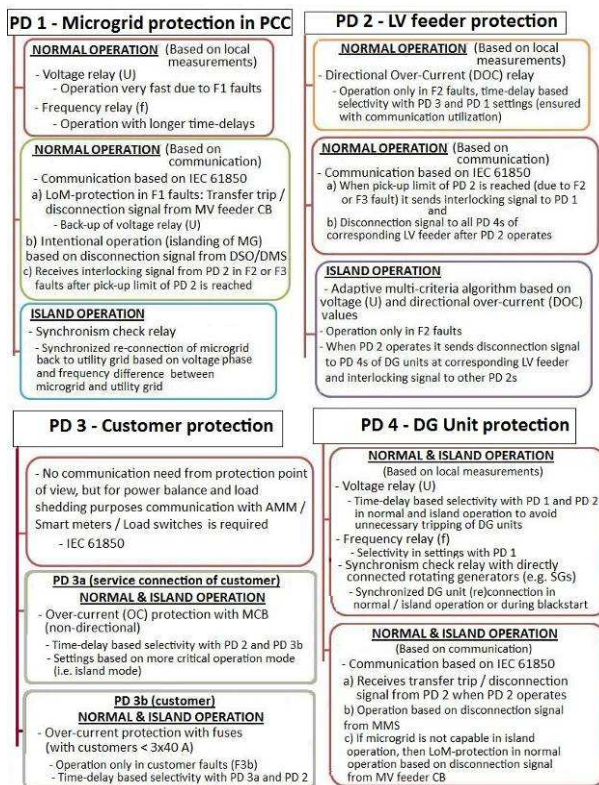

Figure 2. Functions needed for LV microgrid protection in normal and island operation based on local measurements and communication (see Fig. 1).

Fast real-time communication is needed for microgrid protection purposes between protection devices (PD 1 and 2) and also with master unit and DG units during microgrid island operation. In addition MMS needs to be able to

communicate in real-time with all these microgrid components as well as with customer loads. In this paper it has been proposed that this communication should be based on some standard like IEC 61850 (Fig. 1).

Role of MMS is also important in power balance management of island operated microgrid, e.g., after fault F2 at LV feeder, MMS must send immediately after operation of LV feeder protection (PD 2) new set point values for those DG units that are still connected at the healthy part of the microgrid or disconnection signal to some less critical customer loads. In Fig. 2 functions of the proposed new LV microgrid protection system during normal and island operation are presented.

Operation curves of PDs

In the following the operation curves for PDs in the proposed LV microgrid protection system, developed in [2], during normal and island operation are described. One important issue is that operation curves for PD 1 in normal and PD 2 in island operation also represent the fault-ride-through (FRT) requirements for DG units connected to the LV microgrid, because they are created so that stability of LV microgrid or healthy part of LV microgrid could be maintained after fault clearance also in cases where directly connected SG was connected in LV microgrid. Voltage relay operation curve of PD 4 ensures selectivity with settings of PD 1 in normal operation and PD 2 in island operation to avoid unnecessary tripping of DG units. Frequency relay of PD 1 and PD 4 is only used to protect microgrid customers from possible long-term frequency deviations from nominal 50 Hz, e.g., caused by disturbances due to power imbalance in HV network which cannot be seen from phase voltage measurements. Operation curves for frequency relay of PD 4 will also represent FRT requirements for DG and energy storage units with respect to the frequency. Pick-up and operation limits for PD 3s OC settings should be quite low, because their operation speed should be same also in island operation, where fault current level will be much lower than in normal operation.

In Fig. 3 and 4 requirements for the operation of microgrid protection devices (PD 1, PD 2, PD 3 and PD 4) during normal operation of microgrid are presented. The operation limits for low-set and high-set stages of PD 2 and PD 3a in Fig. 4 are instructional, based on simulation studies done in reference [2]. The protection of LV feeders with PD 2s in normal operation is based on directional OC relays (Fig. 4). The direction of the current must be to corresponding LV feeder with such time delay that all possible type of customer faults (F3) will be cleared with PD 3s before possible operation of PD 2. The chosen time delays in Fig. 4 between PD 2 and PD 3a are quite small and selectivity may be hard to achieve between them in reality without communication based interlocking signals from PD 3a. The operation curve for PD 4 must be such that it will never unnecessarily disconnect DG unit due to any type of fault, i.e. PD 4 needs to be time selective with PD 1, PD 2 and PD

3 both in normal and in island operation of microgrid. In reference [2] also an additional operation criteria for PD 4 was specified: disconnection of DG unit with PD 4 based on under-voltage should only take place in less than 150 ms after pick-up limit is reached if voltage in all three phases (A, B, C) is less than 5 % from nominal (see Fig. 3). The voltages for PD 4 are measured from microgrid side of delta-wye grounded transformer.

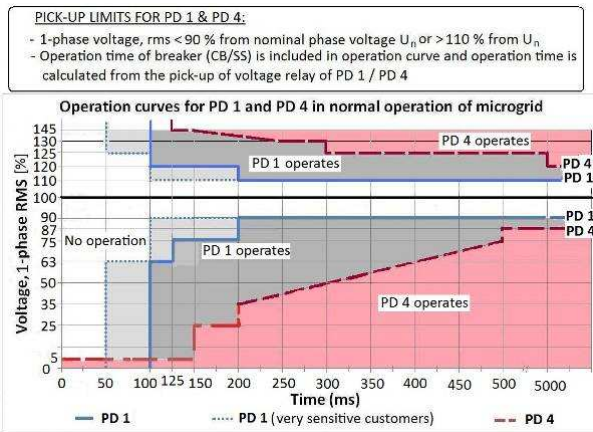

Figure 3. Operation curves for voltage relays (PD 1 in normal operation and PD 4 in normal and island operation).

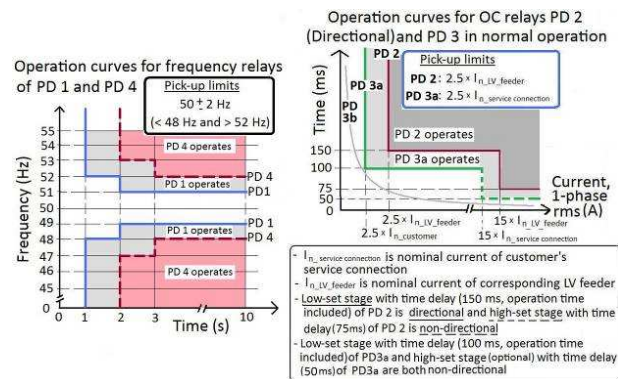

Figure 4. Operation curves frequency relays of PD 1 and PD 4 in normal and island operation of microgrid and operation curves for OC relays of PD 2 (directional low-set stage and non-directional high-set stage) in normal operation and PD 3 in normal and island operation.

Main difference in the protection of LV microgrid during island operation is the change in the protection algorithm of PD 2s. Based on the simulations done in reference [2] adaptive multi-criteria algorithm for PD 2 (Fig. 5) was created.

Adaptivity of PD 2 (Fig. 5) means that during island operation it takes into account the number and type of DG units at corresponding LV feeder and also their fault current feeding capability. In addition, multi-criteria algorithm of PD 2 is based on both phase-to-earth voltage and current measurements. Fast and selective operation between different PD 2s during island operation is achieved by intelligent utilization of high-speed communication. The

settings of PD 3s and PD 4s remains unchanged during island operation of microgrid (see Fig. 3 and 4).

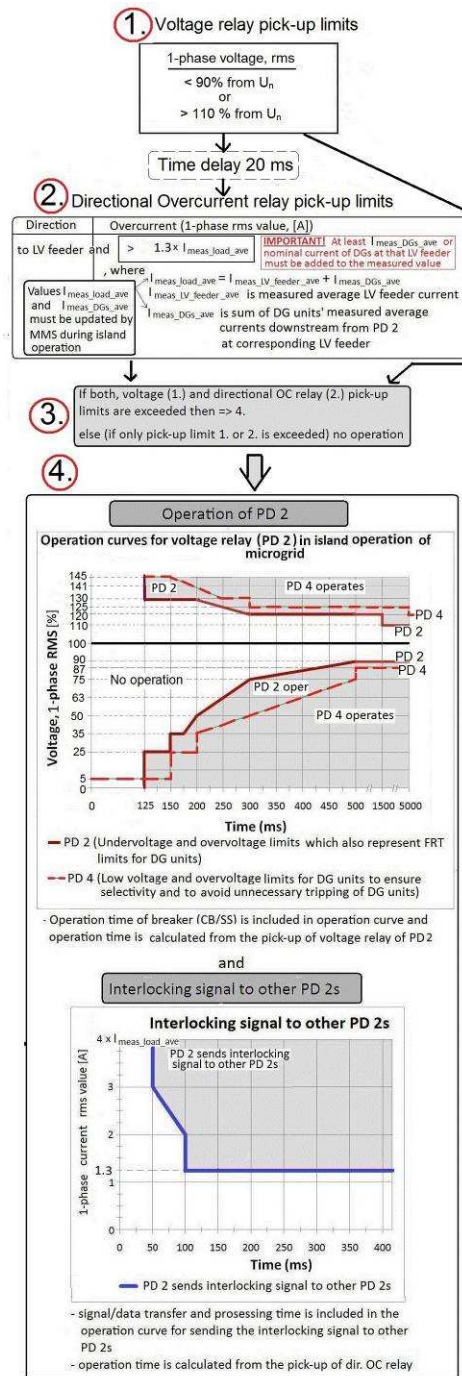

Figure 5. Adaptive multi-criteria algorithm for PD 2 to achieve selective operation during island operation of LV microgrid.

Additions to the proposed LV microgrid protection system

In reference [3] few additions to the proposed LV microgrid system presented in [2] were further developed by considering protection of long LV feeders with section CBs,

connection of large DG units to LV microgrid and protection issues related to possible ring operation of LV feeders.

With longer radially operated LV feeders it may in some cases be beneficial to divide feeders into two protection zones (Fig. 6). In addition, by adding PD_{2ring} (Fig. 6), which is normally open, between LV feeders, the self-healing capability of LV microgrid could be increased. By closing PD_{2ring} (Fig. 6) due to a fault at LV feeder section between PD 2a and PD 2b instantaneously when PD 2a is opened, the number of customers affected by the fault could be reduced. When PD 2a opens due to fault between PD 2a and PD 2b (Fig. 6) it will send closing signal to PD_{2ring} and interlocking signal to other PD 2s, but not until it has opened. On the other hand, if fault occurs after PD 2b at corresponding LV feeder (Fig. 6) PD 2a and PD 2b will detect the fault simultaneously. In this case, to ensure selectivity between PD 2a and PD 2b, PD 2b must send interlocking signal immediately to PD 2a of the same LV feeder before PD 2a operates. In every case during normal and island operation also the selective operation of PD 2a and PD 2b with PD 3 must be ensured.

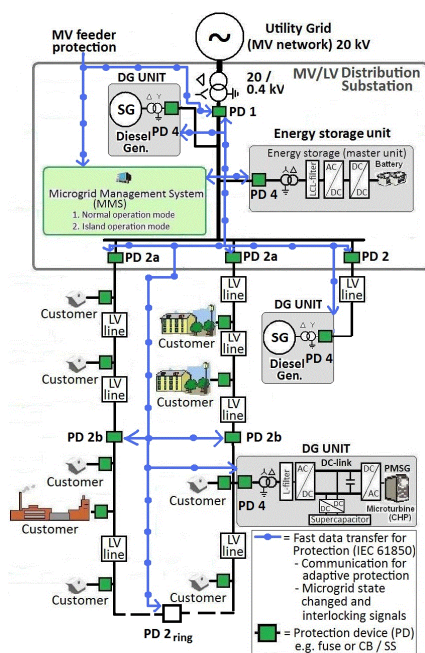

Figure 6. Long LV feeders with section CBs (PD 2b, PD_{2ring}) and connection of large DG units.

Connection of large DG units, e.g., > 50 kVA with high fault current feeding capability directly to LV feeders may in some cases make it challenging to achieve selective protection during island operation of LV microgrid even though adaptive PDs developed in [2] at the beginning of LV feeders were used. Therefore, large DG units should be connected either 1) directly or 2) with own LV feeder to the MV/LV distribution substation (see Fig. 6). Such a DG unit connection is also beneficial for both normal and island operation of LV microgrid if this unit is for example heat

producing CHP unit, because it will always remain connected regardless of possible faults at other LV feeders (Fig. 6).

In normal operation of LV microgrid it can be beneficial from voltage level control point of view to connect LV feeders to ring operation (Fig. 6). This means that PD_{2ring} is needed and it will be closed during normal operation. From the PSCAD simulation results of [3] it became clear that during normal operation of LV microgrid, the selective operation of LV feeder protection PD2a with ring connected LV feeders was not possible without utilization of high-speed communication. However, it was also stated in [3] that to ensure selective operation of microgrid protection also during island operation of LV microgrid the PD_{2ring} (Fig. 6) should always be opened during island operation.

CONCLUSIONS

In this paper novel protection system for LV microgrid, including the operation curves for PDs, during normal and island operation has been presented. In future the flexibility and applicability of the proposed LV microgrid system to different kind of microgrids could be further studied. Realization of LV microgrids as integrated part of future Smart Grids needs new grid codes where the protection requirements and settings for LV microgrids are clearly determined. In the future real-life studies are also needed, but the proposed new protection system for LV microgrids with operation curves of different PDs included could be utilized as basis when future grid codes for LV microgrids are determined. The proposed new LV microgrid protection system revealed the need for fast, accurate, low-cost, and programmable PDs with high-speed communication capability in future smart LV networks.

Acknowledgments

This work was supported by *Smart Grids and Energy Market (SGEM)* research program of CLEEN Ltd, the Strategic centre for science, technology and innovation of the Finnish energy and environment cluster.

REFERENCES

- [1] A. Oudalov, A. Fidigatti, T. Degner, B. Valov, C. Hardt, J. M. Yarza, R. Li, N. Jenkins, B. Awad, F. Van Overbeeke, N. Hatzigiorgiou, M. Lorentzou, 2009, "Novel protection systems for microgrids", *Final version of partial report for WP C (TC2: Technical requirements for network protection) on More Microgrids EU-project*.
- [2] H. Laaksonen, K. Kauhaniemi, 2010, "Smart Protection Concept for LV Microgrid", *International Review of Electrical Engineering (IREE)*, vol. 5, no. 2, 578-592.
- [3] H. Laaksonen, 2010, "Protection Principles for Future Microgrids", *IEEE Transactions on Power Electronics*, vol. 25, no. 12, 2910-2918.