

## IEC61850-BASED LOSS OF MAIN PROTECTION: THE MILANO WI-POWER PROJECT

Maurizio DELFANTI, Valeria OLIVIERI, Mauro POZZI  
Politecnico di Milano, Energy Department - Italy  
[maurizio.delfanti@polimi.it](mailto:maurizio.delfanti@polimi.it)

Massimo AMBROGGI, Oscar ORNAGO  
Thytronic S.p.A. - Italy  
[m.ambroggi@thytronic.it](mailto:m.ambroggi@thytronic.it)

### ABSTRACT

*In the perspective of smart grids, related to the increasing amount of Dispersed Generation (DG), it is recognized that some challenges are to be faced for the protection of distribution networks. Loss-of-main (LoM) protection is one of the most critical issues to be faced in this context, at least for the Italian system.*

*Only an intelligent use of Information and Communication Technology (ICT) will overcome the current limitations of passive and active methods based LoM protections and make possible a larger DG penetration without hindering system security.*

*Milano Wi-Power is a project undertaken by Politecnico di Milano, with the cooperation of A2A, Retelit, Selta and Thytronic, that aims to implement and test IEC 61850-based LoM protection that inherently contains a suitable communication channel and provides absolutely selective protection. The specific goal is to test and validate, both through simulations and field trials, possible communication systems able to connect the protection of line feeder outgoing from primary substations to the LoM protection of DG units along the feeder.*

### INTRODUCTION

Integrating Dispersed Generation (DG) in the grid is the most important challenge of the near future for power systems in most of EU countries. Actually, DG is the only way of exploiting Renewable Energy Sources (RES) for electric production, in the perspective of 20-20-20 targets (see also the recent financing instruments managed jointly by the European Commission, European Investment Bank and Member States "NER300" [1]). Distribution systems are designed for radial operation so that the power flows from upper voltage levels down to customers along the radial feeders: the presence of DG units at distribution level was not considered at the design stage. Nowadays, small DG units are currently increasing in number, as a consequence of incentives and simplification of the access to the grid (fit-and-forget approach). A high degree of penetration of DG as well as RES placement and capacity have considerable impact on operation, control, protection and reliability of the existing power systems and involve a complete redeployment of both active and reactive power flow along distribution network. Several problems have been reported in literature as for protection, management and regulation of distribution networks (voltage control, rapid voltage changes, thermal limits of branches, short

circuit currents, protection tripping etc) [2] [3]: a high degree of DG penetration requires a conceptual revolution. At international level, the direction of evolution is generally identified with the term 'Smart Grid', implying the use of technology to modernize the power grid and solve many potential problems that DG causes. It employs innovative products and services combined with intelligent monitoring, control, communication, and self-healing technologies to facilitate the connection and operation of DG of all sizes and technologies, allow consumers to play a part in optimizing the operation of the system, and allow enhanced levels of reliability and security of supply [4]. The paper is organised as follows: after this introduction, we describe the issues related to the LoM protection. Then, we focus on the features of the Milano Wi-Power project and explain the characteristics of ICT system used to solve the problems of energy networks. We present some results of simulations and, finally, provide some concluding remarks.

### ISSUES RELATED TO LoM PROTECTION

The use of LoM protection is common to almost all EU networks: EN 50438 [6] collects valuable information on LoM protections<sup>1</sup> in use in many countries, with the related settings. In particular, the codes and guidelines vary from country to country but requirements similar to the following are often given:

- a) DG should be disconnected in case of abnormalities in voltage or frequency;
- b) if one or more phases are disconnected from the grid supply, all DG units should be rapidly disconnected from the network;
- c) if auto-reclosing is applied, the DG units must be disconnected before reclosing, to give enough time for the fault arc to extinguish, and to avoid damages to DG units.

### Protection strategies

During the past years many methods for detecting the islanding condition have been proposed and developed. They can be divided into three categories (see [7] and [8]):

- passive methods,
- active methods,
- communication-based methods.

In the first category protection is accomplished by relying solely on the local measurements (at the DG's point of

<sup>1</sup> LoM characteristics given in the EN 50438 are common to DG units connected at MV level.

common coupling PCC). The most traditional passive methods based protections, also used in the Italian electric system (national standard CEI 0-16 [9]), are based on voltage and frequency measurements:

- overvoltage (59);
- undervoltage (27);
- overfrequency (81O);
- underfrequency (81U).

Similarly 81R - Rate Of Change Frequency (ROCOF) and Vector Shift are well known passive protections. However, a major drawback of all this methods is the so-called non-detection zone (NDZ). In other words, passive methods are unable to detect islanding if the power mismatch at the circuit breaker creating the island is small. Moreover they are not able to discriminate between islanding and other events (e.g. disturbances in the HV network or fault in adjacent feeders), so the more NDZ is reduced (with more sensitive settings), the greater the number of nuisance tripping.

Active methods "actively" induce disturbances in the voltage. These methods are especially suitable for generating units which are based on grid inverters.

The third category of LoM detection methods consists of communication-based methods: in the intertrip scheme, the feeder relay located at the substation sends a trip signal to the DG units located along the feeder. For this purpose, a suitable communication channel is needed.

### LoM on Italian distribution networks

LoM protection on the Italian power system has very sensitive settings in terms of frequency thresholds and very fast tripping time (to allow for fast reclosure of MV lines<sup>2</sup>): these characteristics are typical of Italy, but will become common in all countries where power quality levels are to be guaranteed. The operation of such LoM is deemed insufficient for two main causes.

- Currently LoM is based on passive methods, so increasing the penetration of DG up to values such as to reach the power absorbed by loads (Fig. 1) will lead LoM to operate in the NDZ.
- Very sensitive frequency thresholds settings (49,7 Hz - 50,3 Hz, as per CEI 0-16) lead to unwanted trips of the LoM protection, because frequency values so close to 50 Hz are possible also in operating conditions other than islanding. Frequency transients on the transmission network have appeared on November 4th 2006, and affected the entire national transmission grid<sup>3</sup>; a

<sup>2</sup> Fast reclosure (few hundred milliseconds), used only in a some EU systems, is aimed at ensuring higher levels of power quality (in case of non-permanent faults, only a transient interruption is perceived by customers).

<sup>3</sup> This incident, indeed, affected the whole EU electric system, causing similar DG losses in many countries.

significant amount of DG (about 900 MW) has been disconnected by relevant LoM protections. Also faults on adjacent feeders can lead LoM to nuisance tripping.

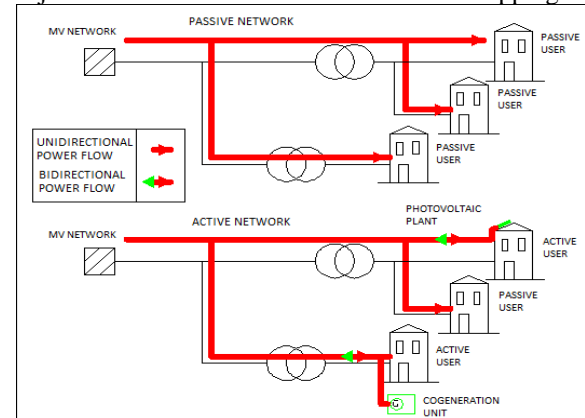

Fig. 1 Power flow on MV network.

### MILANO WI-POWER PROJECT

Only a proper use of communication systems can overcome the above limitations of passive and active methods based LoM protections. It is our opinion that ICT will improve in a decisive way the operation of communication-based LoM protections, making possible a real contribution of DG to the security and reliability of the whole power system.

A research project has been launched at Politecnico di Milano, to study possible ways of exchanging information between the Primary Substation (PS, at the interface between HV and MV, with every MV line equipped with MASTER relay<sup>4</sup>) and the DG units (equipped with SLAVE relay<sup>5</sup>) Fig. 2.

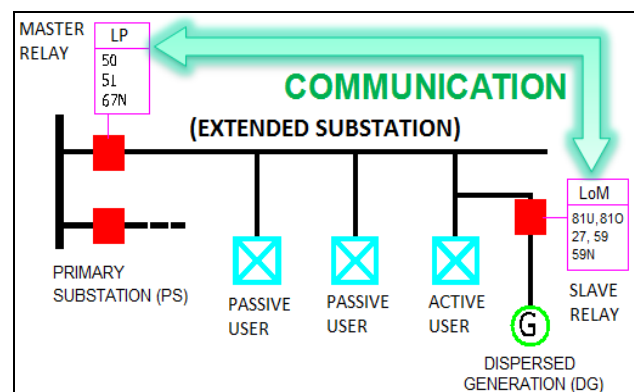

Fig. 2 Communication between PS (master relay) and DG (slave relay).

<sup>4</sup> Line Protection (LP) has overcurrent (50, 51), directional ground fault (67N) protections and autoreclosing function (79).

<sup>5</sup> LoM protection has overfrequency (81O), underfrequency (81U), overvoltage (59), and undervoltage (27) protective functions. These functions serve as backup when communication is not available.

In particular, we consider the 23 kV PS of the Distributor network in the North-West side of Milan (PS Musocco of A2A *reti elettriche*, one of the most important Italian DNO) and a cogeneration site at Politecnico di Milano campus (Fig. 3).



Fig. 3 Test case.

The first stage of the project aims at developing communication systems and innovative LoM protections for DG; eventually, ICT will be exploited also for an enhanced control and management of the distribution system in a scenario of significant penetration of DG.

Communication systems and new LoM for DG are aimed at ensuring the proper disconnection of production systems (reliable anti-islanding), and to avoid the inappropriate interruption of the DG parallel operation.

To reach these goals, two key features of the communication system are:

- extremely short latency (100-200 ms);
- high availability and reliability, even when the electric system faces critical situations (incidents on transmission, blackouts) or faults on external feeders occurs.

The project is testing different communication techniques: fiber optics, power line carrier (PLC), Wi-Fi (to be installed for the purpose of the project), the existing public Internet (Wi-Max, wired network).

The main goal of the project is to exchange information between MASTER and SLAVE relay in order to allow several new functions, affecting both the LoM protection and the DG unit itself. The main innovative functions are:

- 1) a reliable intertrip<sup>6</sup> when loss of main (opening of the feeder circuit breaker in the Primary Substation) appears: this will solve definitely the issues related to the insufficient operation of LoM on Italian network;
- 2) a coordination of voltage regulation by DG if needed;
- 3) a limitation of active power generation by DG if needed.

The last two points allow a further enhancement of the hosting capacity of distribution networks.

<sup>6</sup> Intertrip means that the trip of SLAVE relay is forced if and only if a trip of MASTER relay happens; intertrip is based on a signal exchanged between MASTER and SLAVE relay; the latter does no longer need local measurements of voltage/frequency.

### ICT issues

The first idea was to test non-invasive communication system (the existing Internet; eventually PLC): at least in urban (and sub-urban) contexts such as Milan, the Internet is widely available. On the other hand, the use of PLC on MV networks does not seem to guarantee the availability of the communication channel (with the required latency) during short circuits. It was therefore decided to test the public Internet as first solution: this choice entails considerable economic and practical advantages.

The first tests are based on the existing public Internet: a standard IP connection is used, both at the MASTER and at the SLAVE relay. The use of Internet for controlling DG has already been proposed in literature: difficulties related to cyber security and to availability/reliability of the communication have been highlighted.

About cyber security, a Virtual Private Network (VPN) of level 2 is used to link the master & slave relay; moreover, communication protocols are available, capable of ensuring an adequate level of security: in the tests it is made use of the well-known IEC 61850 protocol [10], originally developed for the management of the HV stations.

### IEC 61850: standard protocol for communication

The IEC 61850 standard is rapidly gaining a significant foothold in electric power utilities. IEC 61850-8-1 specifies the so-called GOOSE (Generic Object Oriented Substation Event) functionality: given performance classes for the GOOSE messages for different applications are specified in IEC 61850-5. Modern protection relays with an implementation of IEC 61850 have opened up possibilities for extending the new approach in the engineering of station-wide protection schemes. The publisher/subscriber method used in GOOSE messaging provides an efficient and fast means of sharing information between all relays in an extended substation. The inherent quality validation of GOOSE messages and the condition monitoring of the physical communication link increase reliability and allow alerting the operator (or even automatically changing the system parameters) in case any abnormalities are detected.

### Test system

During the first tests a testing system (Fig. 4) was setup in the city of Milan at A2A Primary Substation (PS), at the experimental Cogeneration Site (CS) of Politecnico di Milano and at THYTRONIC Laboratories (TL). Multifunction feeder protective relay at PS and LoM protective relay with two setting profiles of 27-59-59N-81O-81U protective functions at CS and TL were installed. All relays are provided by THYTRONIC with "native" GOOSE messages compliant to IEC 61850 standard, so no adapters were used. As for communication channels, VPN (Virtual Private Network) on the public Internet between PS and TL relays (~11 km) and Wi-Max between PS and CS relays (~3 km) were exploited.

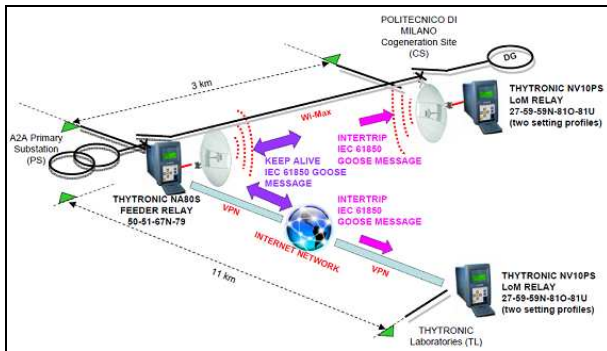

Fig. 4. Schematic test system.

The protective relays implement the following GOOSE messages:

- “Intertrip”, that PS master relay transmits to CS and TL slave relays in order to disconnect DG when loss of main occurs.
- “Keep Alive”, cyclically exchanged between master and slaves relays to monitor the communication channel.

Intertripping is intended as primary LoM protection and it can disconnect DG also if balance between load and generation exist on the faulted feeder (i.e., no NDZ appears). A time limit of 200 ms was admitted between the transmission and reception of intertrip messages; this allows DG being surely disconnected before the first cycle of automatic reclosing (400 ms on the Italian MV distribution network).

When communication is active (“keep alive” received) a low sensitivity setting profile of voltage/frequency protections is enabled in LoM relays (f.i. 49-51 Hz, blue settings in Fig. 5), together with intertripping, in order to disconnect DG only if LoM or a severe transmission network incident occurs. Moreover, with this protective strategies, nuisance tripping for faults on MV external feeders are avoided and DG may contribute to recover emergency conditions of the whole systems.

The proposed architecture operates in a fail-safe mode (Fig. 5): in the presence of the communication system, LoM protection has wider settings (blue area in Fig. 5).

On the other hand, should the communication fail (a keep alive test is performed f.i. every 5 s) the relays come back to the “local” operation (the same of today, red settings in Fig. 5).

Tests have been performed causing the intertrip message transmission from the master relay and measuring the time difference between the relays real time clocks at message transmission and reception. A NTP server was used in order to keep the real time clocks synchronized.

In a second stage, tests are also planned with other communication channels as Power Line Carrier and fiber optics.

Moreover the fast GOOSE messages encourage future advances for IEC 61850-based protective relays (logical selectivity) and DG voltage/power control.

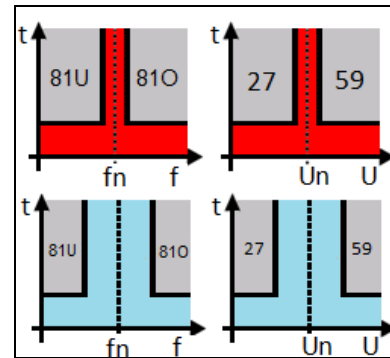

Fig. 5 High sensitive settings, f.i. 49,7 ÷ 50,3 Hz (red) and low sensitive settings, f.i. 49 ÷ 51 Hz (blue) of LoM protection.

With respect to availability/reliability, the initial testing in an urban environment showed a reliability of the data channel fully compatible with the needs of the distribution system: it has to be noticed that the application we propose is related to small/very small size units, widely scattered over the network. When considering the performances of such a system (made up of many small units), a probabilistic criterion has to be used: this allows accepting reliability levels less than ones required for the protection of huge power plants.

**Tests results**

The exchange of information between PS and CS, TL has been tested in terms of reliability and of transmission speed. The first attempt was to use the existing wired Internet between PS and TL: the results are plotted in Fig. 6.

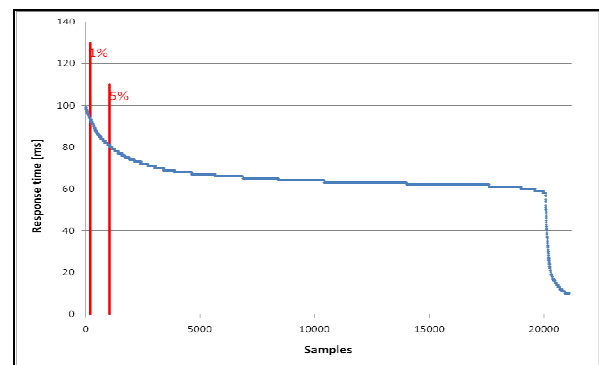

Fig. 6 Public Internet (wired) intertrip results.

In a time span of a whole day, over a distance of about 11 km, more than 20000 intertrip tests have been performed (samples). As shown in the graph, 100% of the tests were successful; the time occurring for a bi-directional communication is shown in the figure (response time), and is less than 100 ms in practically all cases (this is fully compatible with the application, that would work even with a response time of 200 ms).

Further tests were based on Wi-Max link between PS and CS. As for the previous case, an experiment of ten whole days is shown in Fig. 7.



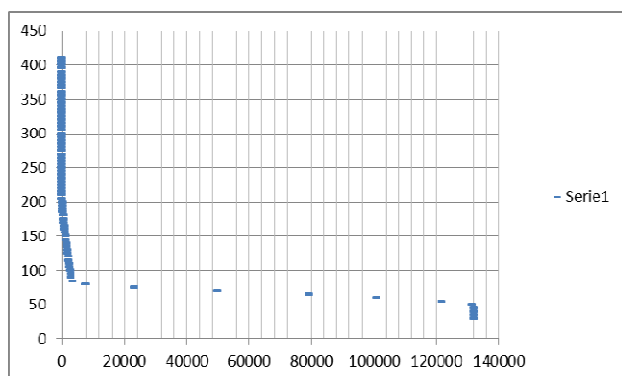

Fig. 7 Public Internet (WiMAX) intertrip results

In this case, more than 92% of the tests were successful in the time required. Considering that no agreement with the provider (in order to have priority for the messages transmitted) was in place, and given the probabilistic approach, these results are fully compatible with the application proposed.

## CONCLUDING REMARKS

A first preliminary indication of the project is to exploit the existing public Internet infrastructure to cover the distances associated with the MV network<sup>7</sup>.

The preliminary findings indicate the perspective to integrate energy and information networks, to exploit the obvious synergies possible, to minimize costs, but also to avoid duplication of infrastructures, with negative impacts on the environment.

Many examples of electricity infrastructure exploitation to support information networks are already in place: HV lines are used as carriers for fiber optic cables, that constitute the backbone of information networks. In perspective, even the MV networks (essentially, those newly installed, or refurbished, when conductors are buried) will be exploited as a support to the information network.

In this new approach, the power grid and the information network would be rather complementary, both in their functions, and in their development: it is conceivable that, in contexts already highly developed, such as urban and suburban areas, the information network is employed as a support function for the electricity network, while in less densely populated environments, new developments in the electricity network can be seen as support for the information network.

The proposed evolution would entail many positive outcomes for the network users: simplification of the connection of DG to the distribution system, less unwanted trips due to LoM protection, greater overall system

<sup>7</sup> For the LV network DG units, the use of PLC systems can also be envisaged: this would entail greater simplicity (and lower cost) which are required for devices associated with very small DG units

reliability, increased safety due to the reduced unwanted islanding, availability of interface devices suitable for operation over active networks, lower losses in the system and better voltage regulation.

Ultimately, the active management of the network is of benefit to all users of the system as it facilitates the connection of DG and allows postponing network investments.

## Acknowledgments

Field tests were possible thanks to the support provided by A2A Reti Elettriche, Retelit (WiMAX facilities) and Selta. The authors wish to thank Luca Lo Schiavo (Italian Regulating Authority, General Direction) and Antonio Capone (Politecnico di Milano) for their valuable comments.

## REFERENCES

- [1] www.ner300.com
- [2] R.C. Dugan, M.F. McGranaghan, S. Santosa, H.W. Beaty, "Electric power systems quality", McGraw-Hill, New York, 2002. Chapter 9: Distributed generation and power quality.
- [3] N. Jenkins, R. Allan, P. Crossley, D. Kirschen, G. Strbac, "Embedded generation", Institution of Electrical Engineers, London, 2000. Chapter 5: Power quality.
- [4] Smart Grid Maturity Model. Software Engineering Institute, Carnegie Mellon University [Online]. Available: <http://www.sei.cmu.edu/smartgrid/index.cfm>
- [5] Resolution ARG/elt 25/09 "Monitoring of the development of distributed generation plants in Italy for the year 2006 and analysis of the possible effects of distributed generation on the national electricity system." [Online]. Available: <http://www.autorita.energia.it/it/docs/09/025-09arg.htm>
- [6] CENELEC, 2007, Technical Standard EN 50438, "Requirements for the connection of micro-generators in parallel with public low-voltage distribution networks".
- [7] K. Maki, A. Kulmala, S. Repo, P. Jarventausta, "Problems related to islanding protection of distributed generation in distribution network", IEEE 2007.
- [8] S.P. Chowdhury, S. Chowdhury, P.A. Crossley, "Islanding protection of active distribution networks with renewable distributed generators: A comprehensive survey", Electrical power system research, Periodical: Electric power system research 79 (2009) 984-992.
- [9] Italian Electrical Committee (CEI), 2008, Technical standard CEI 0-16 "Technical conditions for electricity distribution grid connection with a nominal voltage of greater than 1 kV", in Italian, CEI, Milan.
- [10] CENELEC, 2005, Technical Standard IEC 61850, "Communication networks and systems in substations".